

TIME  
LIFE  
BOOKS

THE ART OF WOODWORKING

# CABINETMAKING





*In Loving Memory*

*Tucker*

*1999-2004*

# WORKSHOP GUIDE

## SAFETY TIPS

### POWER TOOLS

- Wear appropriate safety gear: safety glasses, a face shield for extra protection, and hearing protectors or ear plugs. If there is no dust collection system, wear a dust mask. For exotic woods such as ebony, use a respirator; the sawdust may cause an allergic reaction. Wear work gloves when handling rough lumber.
- Do not use a tool if any part of it is worn or damaged.
- Keep your hands well away from a turning blade or bit.
- Drape the power cord of a portable tool over your shoulder to prevent it from getting in the way and being damaged.

- Concentrate on the job; do not rush. Never work when you are tired, stressed or have been drinking alcohol or using medications that induce drowsiness.
- Keep your work area clean and tidy; clutter can lead to accidents, and sawdust and wood scraps can be a fire hazard.

### HAND TOOLS

- Use the appropriate tool for the job; do not try to make a tool do something for which it was not designed.
- Clamp down a workpiece to free both hands for an operation.
- Cut away from yourself rather than toward your body.

- Do not force a tool; try removing less material, or sharpen the cutting edge.
- Keep the edges of cutting tools sharp.

## ANATOMY OF A BOARD

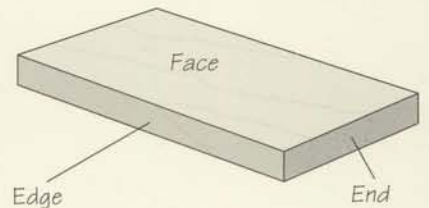

## CABINETMAKING CLAMPS

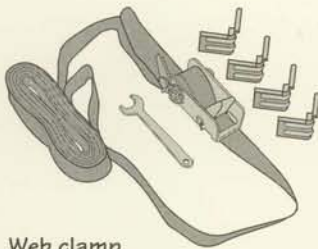

### Web clamp

Also known as band clamp or strap clamp; typically available with strap 15 feet in length. For applying pressure in more than one direction, such as clamping four chair legs at once.

### Quick-action clamp

Also known as cabinetmaker's clamp; typically has a 2½-inch throat depth and a 4-inch span, but also available in larger sizes.



### Spring clamp

Available in a variety of sizes for clamping up to 4 inches; some models have plastic tips to protect stock.



### Double-sided clamp

One side of clamp secured to work surface and other side to stock; features a reach of up to 50 inches depending on the model.



### C clamp

Available in sizes up to 12 inches and with deep throats for extended clamping reach.



### Trigger clamp

Available in spans of 6, 12, 18, 24 and 36 inches; designed to be installed and removed with one hand. Padded jaws protect stock.

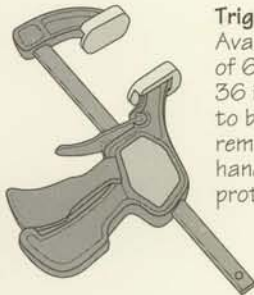

### Handscrew

Also known as screw clamp. Comes in various sizes with jaws that can open up to 16 inches wide.

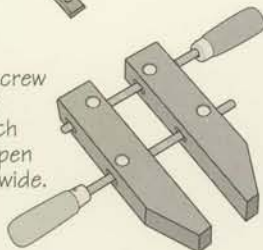

### Pipe clamp

Suitable for clamping longer than 12 inches. Consists of jaws attached to ½- or ¾-inch-diameter pipe; pipe length can be customized to fit a particular span.

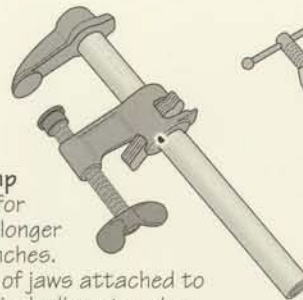

### Bar clamp

Clamps up to 8 feet in length available; more common sizes are 24, 36 and 48 inches.

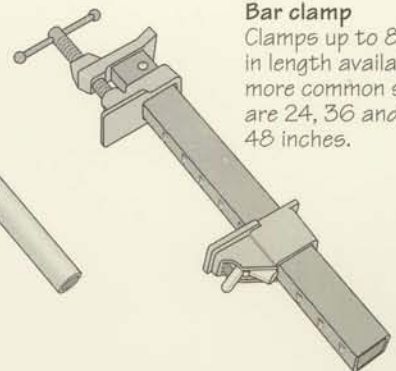

THE ART OF WOODWORKING  
**CABINETMAKING**

THE ART OF WOODWORKING

# CABINETMAKING

TIME-LIFE BOOKS  
ALEXANDRIA, VIRGINIA

---

ST. REMY PRESS  
MONTREAL • NEW YORK

---

THE ART OF WOODWORKING was produced by  
**ST. REMY PRESS**

---

<i>PUBLISHER</i>	Kenneth Winchester
<i>PRESIDENT</i>	Pierre Léveillé
<i>Series Editor</i>	Pierre Home-Douglas
<i>Series Art Director</i>	Francine Lemieux
<i>Senior Editors</i>	Marc Cassini (Text) Heather Mills (Research)
<i>Art Directors</i>	Normand Boudreault, Solange Laberge
<i>Designer</i>	Luc Germain
<i>Research Editor</i>	Jim McRae
<i>Picture Editor</i>	Christopher Jackson
<i>Writers</i>	Tamsin M. Douglas, Andrew Jones
<i>Contributing Writer</i>	Stephen Hart
<i>Contributing Illustrators</i>	Ronald Durepos, Robert Paquet, Studio La Perluète inc.
<i>Administrator</i>	Natalie Watanabe
<i>Production Manager</i>	Michelle Turbide
<i>System Coordinator</i>	Jean-Luc Roy
<i>Photographer</i>	Robert Chartier
<i>Index</i>	Christine M. Jacobs
<i>Proofreader</i>	Judith Yelon

Time-Life Books is a division of Time-Life Inc.,  
a wholly owned subsidiary of  
THE TIME INC. BOOK COMPANY

---

#### TIME-LIFE BOOKS

<i>President</i>	Mary N. Davis
<i>Publisher</i>	Robert H. Smith
<i>Managing Editor</i>	Thomas H. Flaherty
<i>Director of Editorial Resources</i>	Elise D. Ritter-Clough
<i>Associate Publisher</i>	Trevor Lunn
<i>Marketing Director</i>	Regina Hall
<i>Editorial Director</i>	Donia Ann Steele
<i>Consulting Editor</i>	Bob Doyle
<i>Production Manager</i>	Marlene Zack

#### THE CONSULTANTS

**Mark Duginske**, a cabinetmaker who lives in Wausau, Wisconsin, is a contributing editor to *Fine Woodworking* magazine and the author of several books on woodworking power tools.

**Leonard Lee** is the president of Veritas Tools and Lee Valley Tools, manufacturers and retailers of fine woodworking hand tools. He is also the publisher and executive editor of *Woodcuts*, a magazine that focuses on the history and techniques of woodworking.

**Giles Miller-Mead** has taught advanced cabinetmaking at Montreal technical schools for more than ten years. A native of New Zealand, he previously worked as a restorer of antique furniture.

**Joseph Truini** is Senior Editor of *Home Mechanix* magazine. A former Shop and Tools Editor of *Popular Mechanics*, he has worked as a cabinetmaker, home improvement contractor and carpenter.

Cabinetmaking  
p. cm.—(The Art of Woodworking)  
Includes index.  
ISBN 0-8094-9904-5. (trade)  
ISBN 0-8094-9905-3 (lib)  
I. Cabinetwork.  
I. Time- Life Books. II. Series  
TT197.C212 1992  
684'.04—dc20 92-11188  
CIP

For information about any Time-Life book,  
please call 1-800-621-7026, or write:  
Reader Information  
Time-Life Customer Service  
P.O. Box C-32068  
Richmond, Virginia  
23261-2068

© 1992 Time-Life Books Inc.  
All rights reserved.

No part of this book may be reproduced in any form or by any electronic or mechanical means, including information storage and retrieval devices or systems, without prior written permission from the publisher, except that brief passages may be quoted for reviews. First printing. Printed in U.S.A.  
Published simultaneously in Canada.

TIME-LIFE is a trademark of Time Warner Inc. U.S.A.

# CONTENTS

---

- 6 INTRODUCTION**
- 12 CABINETMAKING TECHNIQUES**
- 16 CARCASE CONSTRUCTION**
  - 18 Anatomy of a carcass
  - 20 Making wide panels
  - 27 Carcase joinery
  - 39 Edge banding
  - 41 Shelving
- 44 FRAME-AND-PANEL CONSTRUCTION**
  - 46 Anatomy of a frame-and-panel assembly
  - 48 Making the frame
  - 53 Making the panel
  - 57 Putting the panel in the frame
  - 59 Assembling a frame-and-panel case
  - 60 Installing a bottom panel
  - 61 Shelving
  - 64 Installing a top
  - 69 Installing molding
- 72 DRAWERS**
  - 74 Anatomy of a drawer
  - 76 Drawer joinery
  - 85 Assembling a drawer
  - 87 Mounting a drawer
  - 95 Drawer stops
  - 97 False fronts and hardware
- 100 DOORS**
  - 102 Anatomy of a door
  - 104 Frame-and-panel doors
  - 108 Solid-panel doors
  - 111 Glass doors
  - 113 Veneered-panel doors
  - 115 Hanging a door
- 120 LEGS**
  - 122 Anatomy of a cabriole leg
  - 124 Cabriole legs
  - 128 Tapered and octagonal legs
  - 131 Inlays and detailing
  - 133 Leg joinery
- 140 GLOSSARY**
- 142 INDEX**
- 144 ACKNOWLEDGMENTS**